

***Design Guide for Cold-Formed Steel Beams
with Web Penetrations***

**American Iron and Steel Institute
1101 17th Street, NW, Ste. 1300
Washington, DC 20036-4700**

**For more information on residential steel framing,
call 800-79-STEEL.**

[@Seismicisolation](#)

***Design Guide for Cold-Formed Steel Beams
with Web Penetrations***

August 1997

Prepared for:

**American Iron and Steel Institute
1101 17th Street, NW, Ste. 1300
Washington, DC 20036-4700**

Prepared by:

**Roger A. LaBoube, Ph.D., P.E.
University of Missouri-Rolla
Dept. of Civil Engineering
Rolla, MO 65401-0249**

Copyright 1997

@Seismicisolation

INTRODUCTION

This publication was developed by Roger A. LaBoube, University of Missouri-Rolla for the American Iron and Steel Institute with guidance from the AISI Residential Advisory Group. It is intended to provide design guidelines for the determination of the strength of a cold-formed steel flexural member with a web penetration. AISI believes that the information contained in this publication substantially represents industry practice and related scientific and technical information, but the information is not intended to represent an official position of AISI or to restrict or exclude any other construction or design technique.

American Iron and Steel Institute

Copyright 1997 by American Iron and Steel Institute

[@Seismicisolation](#)

The following publication has been developed by the American Iron and Steel Institute (AISI) which is comprised of representatives of steel producers in the US, Canada and Mexico. In the production of this publication, due diligence has been exercised in consulting a wide range of pertinent authorities and experiences and efforts have been made to present accurate, reliable and useful information. AISI acknowledges the principal author of this publication, Roger A. LaBoube and reviewers.

The materials set forth herein are for general information only. They are not to substitute for competent professional assistance. Application of this information to specific project or setting should be reviewed by a qualified individual. In some or all jurisdictions, such review is required. Anyone making use of the information set forth herein does so at his or her own risk and assumes any resulting liability.

Design Guide for Cold-Formed Steel Beams with Web Penetrations
August 1997



Copyright 1997 by the American Iron and Steel Institute

[@Seismicisolation](#)

CONTENTS

NOMENCLATURE	1
INTRODUCTION	3
DESIGN GUIDELINES	3
Bending Alone	3
Shear Alone	4
Combined Bending and Shear	4
Web Crippling	5
Combined Bending and Web Crippling	6
COMMENTARY ON DESIGN GUIDELINES	7
REFERENCES	7
EXAMPLE PROBLEM NO. 1	9
Check Bending Alone	10
Check Shear Alone	11
Check Combined Bending and Shear	12
Check Web Crippling Alone	12
Check Combined Bending and Web Crippling	13
EXAMPLE PROBLEM NO. 2	14



NOMENCLATURE

The following symbols are used in this design guide. For additional clarification of symbols, see Figure 1.

F_y	= specified minimum yield stress
M	= applied bending moment
M_a	= allowable bending moment
M_n	= nominal bending moment
N	= length of bearing
P	= applied concentrated load or reaction
P_a	= allowable concentrated load or reaction for web crippling alone
R_c	= reduction factor for web crippling
S_e	= effective section modulus
V	= applied shear force
V_a	= the allowable shear strength computed per Specification Section C3.2
V_{a1}	= allowable shear strength adjusted for penetration
V_1	= largest applied shear force at the edge of a penetration
V_2	= smallest applied shear force at the edge of a penetration
a	= depth of web penetration
b	= length of web penetration
c	= web measurement above the web penetration
h	= depth of flat portion of web
q_s	= reduction factor for web penetration
t	= steel base material thickness (uncoated)
x	= nearest distance between the penetration edge and edge of bearing

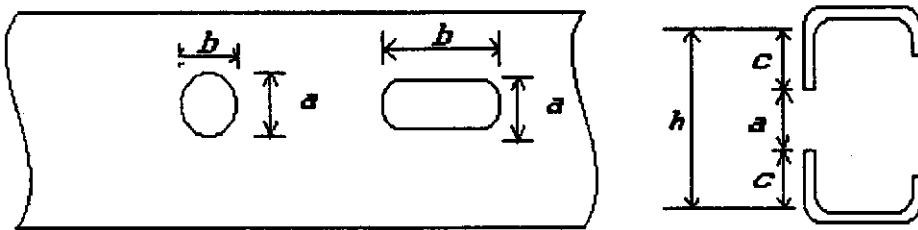
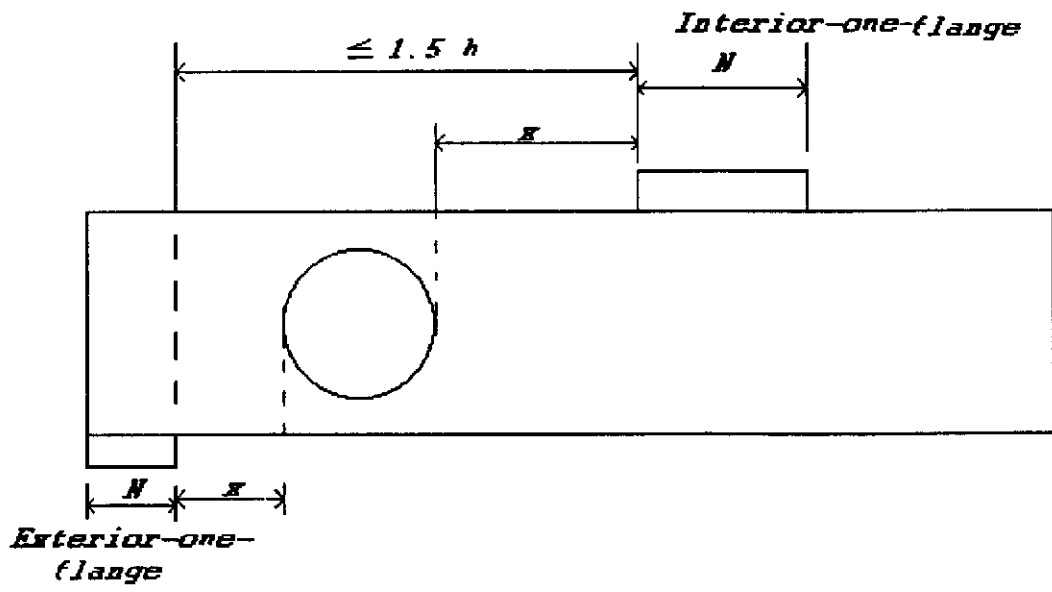

Figure 1. Definition of common symbols



INTRODUCTION

Cold-formed steel members are being more widely used in commercial and residential applications. With the broader acceptance of cold-formed steel members comes additional design issues. A construction issue prevalent in both commercial and residential construction is the ability of the framing system to accommodate the installation of utilities necessary for human occupancy.

To facilitate the passing of utilities, manufacturers of cold-formed steel wall studs and joists punch holes in the web of the cross section. Because these holes are punched during the manufacturing process, their size and location have been defined. However, to install utilities, construction often demands more flexibility in size and location of penetrations.

Researchers have been studying the behavior of flexural members with web openings with the goal of formulating a comprehensive set of design guidelines. This document presents design guidelines for the determination of the strength of a cold-formed steel flexural member with a web penetration. Limit states of bending, shear, and web crippling as well as combinations of (1) bending and shear and (2) bending and web crippling are addressed. In addition to the design guidelines, a brief discussion of the research that serves as the foundation for this information is presented in a Commentary.

DESIGN GUIDELINES

These Guidelines apply only to members designed in accordance with the AISI Specification for the Design of Cold-Formed Steel Structural Members, 1986, with 1989 Addendum, hereafter referred to as the Specification. This is an allowable stress design (ASD) format, and the Guidelines are presented accordingly. As such, they must be used with nominal (unfactored) loads specified by applicable codes. However the Commentary indicates how the Guidelines may be adapted to a load and resistance factor (LRFD) format. These Guidelines require strength calculations to determine the effect of a web perforation, whether the perforation is made during the manufacturing process or in the field.

The Guidelines are applicable to members subjected to bending and shear, such as floor joists. For axially loaded members see the Specification. The Guidelines apply to C-section members with a web depth-to-thickness ratio (h/t) not exceeding 200 and a web perforation depth-to-height ratio (a/h) not exceeding 0.75. The perforation is assumed to be centered at the mid-depth of the web. If the actual perforation is offset, the design may assume a fictitious mid-depth perforation that includes the actual perforation.

Web perforations shall have a center-to-center spacing at least three times the depth of the member, but the spacing need not exceed 24 in. Non-circular holes shall have a length no more than 2.67 times the depth of the penetration. Circular holes shall have a diameter of not more than 6 in.

Special analyses or tests are required if any of the prescribed limits are exceeded.

Bending Alone

The allowable moment capacity, M_a , shall be calculated as follows:

$$M_a = M_n / 1.67 \quad (1)$$

The nominal cross-section moment capacity, M_n , shall be evaluated by the following equation:



$$M_n = S_e F_y \tag{2}$$

where

- F_y = specified minimum yield stress
- S_e = effective section modulus
- a = depth of web penetration
- h = depth of flat portion of web

When $a/h < 0.4$, M_n and S_e shall be computed using the provisions of the Specification, Section C3.1.1(a). This requires that the section modulus be calculated for an effective section with the extreme compression or tension fiber at the yield stress. Thus, the effective width of the flange and the edge stiffener must be determined by the provisions of the Specification, Section B. When $a/h < 0.4$, it is permissible to ignore the penetration and use the gross web section in calculating S_e .

When $a/h \geq 0.4$, M_n is calculated by Equation 2, but the effect of the web penetration must be considered in computing S_e . Specifically, S_e shall be determined using the effective width of the compression portion of the web above the web penetration (below the web penetration for applicable loadings), computed as an unstiffened compression element with k taken as 0.43 (see Specification, Section B3.2). Also, the effective width of the flange and the edge stiffener must be determined by the provisions of the Specification, Section B. When $a/h \geq 0.4$, the penetration shall be deducted from the web section in calculating S_e .

Shear Alone

The applied shear force shall not exceed the allowable shear force, V_{a1} , calculated as follows:

$$V_{a1} = q_{s1} q_{s2} V_a \tag{3}$$

when $c/t \geq 54$

$$q_{s1} = 1.0$$

$$q_{s2} = 1.0$$

(4)

when $5 \leq c/t < 54$

$$q_{s1} = c/t/54$$

$$q_{s2} = 1.5(V_1/V_2) - 0.5 \leq 1.3$$

$$q_{s1} \times q_{s2} \leq 1.0$$

where

- c = $h/2 - a/2.83$ for circular web penetrations
- = $h/2 - a/2$ for all other web penetrations

t = steel base material thickness (uncoated)

V_1/V_2 = variation in shear along the longitudinal axis of the web penetration. V_1 is the larger shear and V_2 is the smaller shear at the edges of the penetration

V_a = the allowable shear strength computed per Specification Section C3.2

Combined Bending and Shear

Unreinforced webs subjected to a combination of bending and shear shall satisfy the following equation:



$$(M/M_a)^2 + (V/V_{a1})^2 \leq 1.0 \tag{5}$$

where

- M = applied bending moment
- M_a = allowable moment computed for bending alone
- V = applied shear force
- V_{a1} = allowable shear strength computed for shear alone

Web Crippling

Webs of flexural members subject to concentrated load or reactions shall be designed for crippling according to Specification Section C3.4, except that the allowable web crippling load P_a, shall be multiplied by a reduction factor, R_c, determined by the applicable equation given below.

A. Web Without Stiffeners, One-Flange Loading

For end-one-flange loading conditions when the penetration is not within the bearing length:

$$R_c = 1.01 - 0.325(a/h) + 0.083(x/h) \leq 1.0 \tag{6}$$

where

- a = depth of web penetration
- h = depth of flat portion of web
- x = nearest distance between the penetration edge and edge of bearing

For interior-one-flange loading conditions when the penetration is not within the bearing length:

$$R_c = 0.900 - 0.047(a/h) + 0.053(x/h) \leq 1.0 \tag{7}$$

For interior-one-flange conditions with coincident centerlines of interior-one-flange load and symmetric penetration:

$$R_c = [1 - 0.197(a/h)^2][1 - 0.127(b/n_1)^2] \leq 1.0 \tag{8}$$

where

- n₁ = N+h-a.
- b = length of web penetration

For interior-one-flange conditions when the penetration is within the bearing length and not coincident and symmetric with load use the smaller of the following:

$$R_c = 0.900 - 0.047(a/h) \leq 1.0 \tag{9}$$

$$R_c = [1 - 0.197(a/h)^2][1 - 0.127(b/n_1)^2] \leq 1.0 \tag{10}$$

B. Webs With Stiffeners, One-Flange Loading

Where stiffeners are used to transmit the concentrated loads or reactions, the calculations of P_a and R_c shall not be required. The stiffener shall have a cross section equivalent to the member cross section. For both end-one-flange and interior-one-flange conditions, the full-depth stiffener must extend the length of the bearing, N. The attachment of the stiffener to the member shall be



Web Design Guide

as close to the top and bottom of the member as possible.

C. Two-Flange Loading

For two-flange loading conditions, tests must be conducted in accordance with Section F1 of the Specification.

Combined Bending and Web Crippling

C-sections without web stiffeners subjected to a combination of bending and concentrated load or reaction shall be designed to meet the following:

$$1.2 (P/R_c P_a) + (M/M_a) \leq 1.5 \quad (11)$$

where

- P = applied concentrated load or reaction
- P_a = allowable concentrated load or reaction for web crippling alone
- M = applied bending moment
- M_a = allowable moment computed for bending alone
- R_c = web crippling reduction factor



COMMENTARY ON DESIGN GUIDELINES

This design guide is based on a review of the engineering literature, and summarizes design solutions, or guidelines, pertinent to cold-formed steel web elements with openings. It has been documented in the literature that the presence of a web opening may have debilitating effect on the structural integrity of a web element. Because the design of uniformly compressed stiffened elements with openings is addressed elsewhere (Specification, 1986; CCFSS, 1994), only flexural member behavior is considered by the design guide.

Studies of the behavior of web elements with openings at the University of Missouri-Rolla (UMR) serve as the basis for the design recommendations for bending alone, shear, web crippling, and combinations of bending and shear and bending and web crippling (Shan et al., 1994; Langan et al., 1994; Uphoff, 1996; Deshmukh, 1996).

The UMR design recommendations are based on tests of full-scale C-section beams having h/t ratios as large as 200 and a/h ratios as large as 0.80. The test program considered both industry standard web openings, rectangular with fillet corners, as well as circular openings. The industry standard openings were punched during the rolling process, whereas the circular holes were cut using a hole saw. The circular openings simulated field cut holes. Three hole diameters, 2-in., 4-in., and 6-in., were studied in both 6-in. and 8-in. deep C-section beams.

Schuster et al. (1995) and Shan et al. (1994), investigated the degradation in web shear strength due to the presence of a web penetration. The test program considered a constant shear distribution across the penetration, and included a/h ratios ranging from 0.20 to 0.78, and h/t ratios of 91 to 168. Schuster's q_s equation was developed with due consideration for the potential range of both punched and field cut holes. Three hole geometries, rectangular with corner fillets, circular, and diamond, were considered in the test program. Eiler (1997) extended the work of Schuster and Shan and studied the behavior of web elements with linearly varying shear along the longitudinal axis of the penetration. The development of Eiler's reduction factors, q_{sl} and q_{sl} , utilized the test data of both Schuster et al. (1995) and Shan et al. (1994).

The provisions of the design guide have been presented in an allowable stress design format but are adaptable to the load and resistance factor design format (Load, 1991). In such case the reduction factors are to be multiplied by the respective nominal strength capacities. For example, for shear alone, q_s would be applied to the nominal shear capacity, V_n , or for web crippling, R_c would be applied to the nominal web crippling capacity, P_n . The load and resistance factor design interaction equations are applicable using the reduced bending, shear, and web crippling capacities.

REFERENCES

CCFSS Technical Bulletin (1994), Center for Cold-Formed Steel Structures, Vol. 3, No. 1, University of Missouri-Rolla, Rolla, MO

Deshmukh, S. U. (1996), "Behavior of Cold-Formed Steel Web Elements with Web Openings Subjected to Web Crippling and a Combination of Bending and Web Crippling for Interior-One-Flange Loading," thesis presented to the faculty of the University of Missouri-Rolla in partial fulfillment for the degree Master of Science.



Web Design Guide

Eiler, M. R. (1997), "Behavior of Web Elements with Openings Subjected to Linearly Varying Shear," thesis presented to the faculty of the University of Missouri-Rolla in partial fulfillment for the degree Master of Science.

Langan, J. E., LaBoube, R. A., and Yu, W. W. (1994), "Structural Behavior of Perforated Web Elements of Cold-Formed Steel Flexural Members Subjected to Web Crippling and a Combination of Web Crippling and Bending," Final Report, Civil Engineering Series 94-3, Cold-Formed Steel Series, Department of Civil Engineering, University of Missouri-Rolla

Load and Resistance Factor Design Specification for Cold-Formed Steel Structural Members (1991), American Iron and Steel Institute, Washington, D.C.

Schuster, R. M., Rogers, C. A., and Celli, A. (1995), "Research into Cold-Formed Steel Perforated C-Sections in Shear," Progress Report No. 1 of Phase I of CSSBI/IRAP Project, Department of Civil Engineering, University of Waterloo, Waterloo, Ontario Canada

Shan, M. Y., LaBoube, R. A., and Yu, W. W. (1994), "Behavior of Web Elements with Openings Subjected to Bending, Shear and the Combination of Bending and Shear," Final Report, Civil Engineering Series 94-2, Cold-Formed Steel Series, Department of Civil Engineering, University of Missouri-Rolla

Specification for the Design of Cold-Formed Steel Structural Members (1986), 1986 Edition with 1989 Addendum, American Iron and Steel Institute, Washington, D.C.

Uphoff, C. A., "Structural Behavior of Circular Holes in Web Elements of Cold-Formed Steel Flexural Members Subjected to Web Crippling for End-One-Flange Loading," thesis presented to the faculty of the University of Missouri-Rolla in partial fulfillment for the degree Master of Science.

Example Problem No. 1

Check the adequacy of the eight inch deep C-section for the AISI Specification design requirements.

The applied service dead plus live loads are as follows:

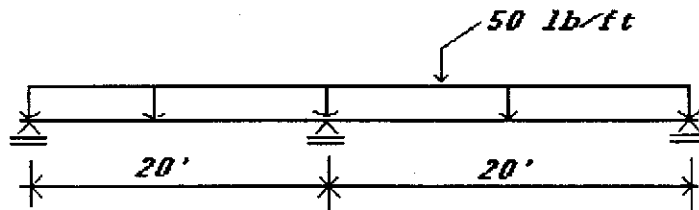

The corresponding shear diagram:

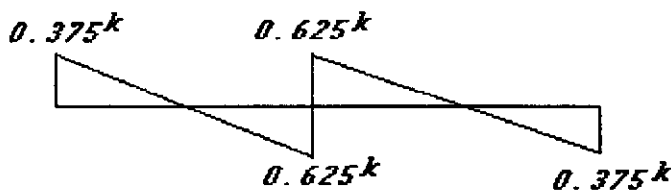

The moment diagram:

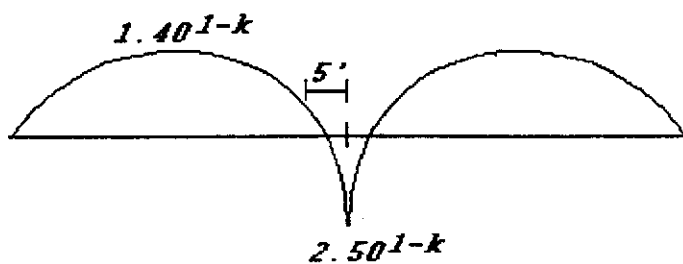

The C-section cross section and support conditions:

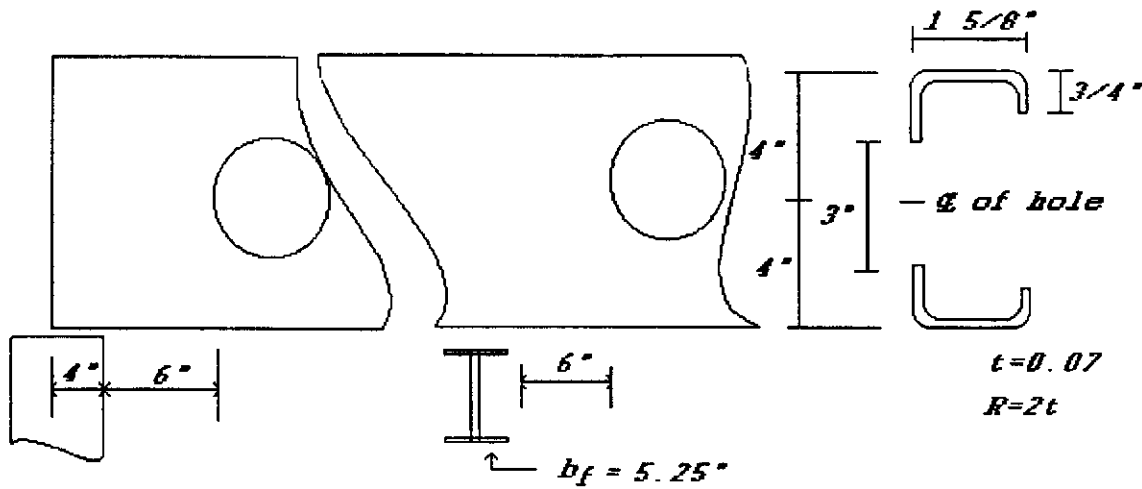

Assume: A653 Gr33 Steel
 Applied Load = 50 lb/ft (dead + live)
 Joist attached to plywood at 12 in. O.C.

Check Bending Alone

In the region of the positive moment, the bending strength is governed by initiation of yielding of the cross section.

$$a = 3 \text{ in.}, h = 8 - 2(0.14 + 0.07) = 7.58 \text{ in.}$$

$$a/h = 3 / 7.58 = 0.396 < 0.40$$

Evaluate the nominal moment capacity, M_n , using the provisions of Specification Section C3.1.1 (a). It is permissible to ignore the penetration and use the gross web section because $a/h < 0.4$.

$$S_f = 1.826 \text{ in.}^3$$

$$M_n = S_{xc} F_y = 1.826 \times 33 = 60.26 \text{ in.-kips}$$

$$M_a = M_n / \Omega = 60.26 / 1.67 = 36.08 \text{ in.-kips} = 3.01 \text{ ft-kips}$$

$$M_{max} = 1.40 \text{ ft.-kips} < M_a$$

The joist is adequate for bending alone in the region of the positive moment.

In the region of the negative moment between the center of the support and the inflection point, conservatively treat the section as an unbraced cantilever.

Determine the allowable moment using the distance from the center of the support to the



inflection point as the unbraced length per Section C3.1.2(a) with $C_b = 1.0$.

$$L = 5 \text{ ft.} = 60 \text{ in.}$$

$$\sigma_t = [GJ + \pi^2 EC_w / (K_t L_t)^2] / A r_o^2 = [11,300 \times 0.00139 + \pi^2 \times 29,500 \times 3.671 / (1.0 \times 60)^2] / (0.852)(3.153)^2 = 36.91 \text{ ksi}$$

$$\sigma_{ey} = \pi^2 E / (K_y L_y / r_y)^2 = \pi^2 \times 29,500 / (1.0 \times 60 / 0.573)^2 = 26.55 \text{ ksi}$$

$$M_c = C_{br} r_o A \sqrt{\sigma_{ey} \sigma_t} = 1.0 \times 3.153 \times 0.852 \sqrt{36.91 \times 26.55} = 84.09 \text{ in.-kips}$$

$$M_y = S_f F_y = 1.826 \times 33 = 60.26 \text{ in.-kips}$$

$$M_c = M_y [1 - M_y / 4M_c] = 60.26 [1 - 60.26 / 4 \times 84.09] = 49.46 \text{ in.-kips}$$

$$f = M_c / S_f = 49.46 / 1.826 = 27.09 \text{ ksi}$$

Because $a/h < 0.40$, it is permissible to ignore the penetration and use the gross web area when computing S_f .

$$S_c = 1.826 \text{ in.}^3$$

$$M_n = S_c M_c / S_f = 1.826 \times 27.09 = 49.46 \text{ in.kips}$$

$$M_a = M_n / \Omega = 49.46 / 1.67 = 29.62 \text{ in.-kips} = 2.47 \text{ ft-kips}$$

$$M_{max} = 2.50 \text{ ft-kips}$$

M_a and M_{max} are essentially equal, thus the joist is adequate for bending alone.

Check Shear Alone

$$h/t = 7.58/0.07 = 108$$

$$1.38 \sqrt{E k_v / F_y} = 1.38 \sqrt{29,500 \text{ ksi} \times 5.34 / 33 \text{ ksi}} = 95$$

$h/t > 95$, Use Specification Eq. C3.2-2

$$V_a = 0.53 E k_v t^3 / h = 0.53 \times 29500 \times 5.34 \times 0.07^3 / 7.58 = 3.78 \text{ kips}$$

$$c = h/2 - a/2.83 = 7.58/2 - 3/2.83 = 2.73 \text{ in.}$$

$$q_{sl} = c / (54 t) = 2.73 / (54 \times 0.07) = 0.72$$

$$V_1 = 0.589 \text{ kips at 6'' from the edge of the interior support}$$

$$V_2 = 0.577 \text{ kips at 9'' from the edge of the interior support}$$



Web Design Guide

$$q_{s2} = 1.5 (V_1/V_2) - 0.5 = 1.5 (0.589/0.577) - 0.5 = 1.03 < 1.3$$

$$V_{a1} = V_a q_{s1} q_{s2} = 3.78 \times 0.72 \times 1.03 = 2.80 \text{ kips}$$

$$V_{\max} = 0.625 \text{ kips} < V_{a1}, \text{ the joist is adequate for shear alone}$$

Check Combined Bending and Shear

$$(M/M_a)^2 + (V/V_{a1})^2 \leq 1.0$$

$$(30 / 36.08)^2 + (0.625 / 2.80)^2 = 0.74 < 1.0, \text{ the joist is adequate for bending and shear}$$

Check Web Crippling Alone

End-One-Flange Condition: Use Specification Eq. C3.4-1

$$k = F_y / 33 = 33 / 33 = 1.0$$

$$C_3 = 1.33 - 0.33 k = 1.0$$

$$C_4 = 1.15 - 0.15 R/t = 1.15 - 0.15 \times 0.14 / 0.7 = 0.85$$

$$C_\Theta = 0.7 + 0.3 (\Theta/90)^2 = 0.7 + 0.3 (90/90)^2 = 1.0$$

$$P_a = t^2 k C_3 C_4 C_\Theta [179 - 0.33 h/t] [1 + 0.01 N/t] \\ = (0.07)^2 \times 1.0 \times 1.0 \times 0.85 \times 1.0 [179 - 0.33 \times 108] [1 + 0.01 \times 4 / 0.07] = 0.938 \text{ kips}$$

$$R_c = 1.01 - 0.325 (a/h) + 0.083 (x/h) \\ = 1.01 - 0.325 \times 0.396 + 0.083 \times 6 / 7.58 = 0.947$$

$$P_a R_c = 0.938 \times 0.947 = 0.888 \text{ kips}$$

$R_{\max} = 0.375 \text{ kips} < P_a R_c$, the joist is adequate for web crippling at the wall supports

Interior-One-Flange Condition: Use Specification Eq. C3.4-4

$$N/t = 5.25 / 0.07 = 75 > 60, \text{ Use } [0.75 + 0.011 N/t]$$

$$C_1 = 1.22 - 0.22 k = 1.22 - 0.22 \times 1.0 = 1.0$$

$$C_2 = 1.06 - 0.06 R/t = 1.06 - 0.06 \times 0.14 / 0.07 = 0.94$$

$$C_\Theta = 1.0$$

$$P_a = t^2 k C_1 C_2 C_\Theta [291 - 0.04 h/t] [0.75 + 0.011 N/t] \\ = (0.07)^2 \times 1.0 \times 1.0 \times 0.94 \times 1.0 [291 - 0.04 \times 108] [0.75 + 0.011 \times 5.25 / 0.07] \\ = 2.08 \text{ kips}$$

$$R_c = 0.90 - 0.047 (a/h) + 0.053 (x/h) \\ = 0.90 - 0.047 \times 0.396 + 0.053 \times 6 / 7.58 = 0.92$$



$$P_a R_c = 2.08 \times 0.92 = 1.91 \text{ kips}$$

$R_{\max} = 1.25 \text{ kips} < P_a R_c$, the joist is adequate for web crippling at the interior support.

Check Combined Bending and Web Crippling

$$1.2 (P / R_c P_a) + (M / M_a) \leq 1.5$$

$$1.2 \times 1.25 / 1.91 + 30 / 36.08 = 1.62 > 1.5$$

The joist is inadequate at the interior support for the combination of bending and web crippling. The most economical solution is to add a bearing stiffener at the interior support location on the C-section.

Example Problem No. 2

Compute the allowable moment capacity, M_n , for the C-section.

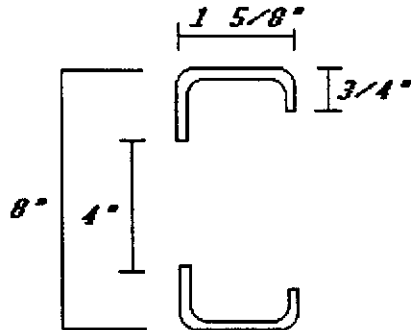

$$t = 0.07 \text{ in.}$$

$$R = 2t = 0.14 \text{ in.}$$

$$h = 8 - 2(0.14 + 0.07) = 7.58 \text{ in.}$$

$$a/h = 4 / 7.58 = 0.528 > 0.4$$

Therefore, the section modulus must be determined for the net section, treating the area above the penetration as an unstiffened element.

$$F_y = 50 \text{ ksi}$$

Compression Flange:

Specification Section B4.2 applies.

$$w = 1.625 - 2(0.14 + 0.07) = 1.205 \text{ in.}$$

$$w/t = 1.205 / 0.07 = 17.214 < 60$$

$$S = 1.28\sqrt{E/f} = 1.28 \sqrt{29,500 / 50} = 31.09$$

$$S/3 = 31.09 / 3 = 10.36 < w/t = 17.21 < S = 31.09$$

Specification Section B4.2 Case II applies.

$$I_a = 399 \{ [w/t/S] - 0.33 \}^3 t^4 \\ = 399 \{ [17.21/31.09] - 0.33 \}^3 (0.07)^4 = 0.000107 \text{ in.}^4$$

$$D = 0.75 \text{ in.}$$

$$d = 0.75 - 0.14 + 0.07 = 0.54 \text{ in.}$$



Web Design Guide

$$I_s = d^3 t / 12 = (0.54)^3 \times 0.07 / 12 = 0.000919 \text{ in.}^4$$

$$I_s / I_a = 0.000919 / 0.000107 = 8.584$$

$$D/w = 0.75 / 1.205 = 0.622$$

$$n = 1/2$$

$$\begin{aligned} k &= [4.82 - 5 D/w] (I_s / I_a)^n + 0.43 \leq 5.25 - 5 D/w \\ &= [4.82 - 5 \times 0.622] (8.584)^{1/2} + 0.43 \leq 5.25 - 5 \times 0.622 = 5.44 \leq 2.14 \end{aligned}$$

Use $k = 2.14$

$$\begin{aligned} \lambda &= (1.052 / \sqrt{k}) (w/t) \sqrt{f/E} \\ &= (1.052 / \sqrt{2.14}) \times 17.21 \sqrt{50 / 29,500} = 0.510 < 0.673 \end{aligned}$$

$$b = w = 1.205 \text{ in.}$$

Compression Edge Stiffener:

Specification Section B4.2 Case II applies.

$$k = 0.43$$

$$d/t = 0.54 / 0.07 = 7.714$$

$$\lambda = (1.052 / \sqrt{0.43}) \times 7.714 \sqrt{50 / 29,500} = 0.509 < 0.673$$

Therefore, $d_s' = d$

$$d_s = d_s' (I_s / I_a) \leq d_s', \text{ however, } (I_s / I_a) > 1.0$$

Therefore, $d_s = d = 0.54 \text{ in.}$

Compression Portion of the Web:

Because $a/h = 4 / 8 = 0.5 > 0.4$, the section modulus must be determined by assuming the area of the web above the penetration is an unstiffened compression element.

$$k = 0.43$$

$$w = (7.58 - 4) \times 0.5 = 1.79 \text{ in.}$$

$$w/t = 1.79 / 0.07 = 25.57$$

$$\lambda = (1.052 / \sqrt{0.43}) \times 25.57 \sqrt{50 / 29,500} = 1.689 > 0.673$$

$$\begin{aligned} \rho &= (1 - 0.22/\lambda) / \lambda \\ &= (1 - 0.22 / 1.689) / 1.689 = 0.515 \end{aligned}$$



$$b = \rho_w = 0.515 \times 1.79 = 0.922 \text{ in.}$$

Using the previously computed effective widths for the compression elements (flange, edge stiffener, and web), calculate the effective section modulus, S_e .

Element	L	y	Ly	Ly^2	I_1'
web-comp.	0.922	0.671	0.619	0.415	0.065
Web-tension	1.790	6.895	12.342	85.098	0.478
Upper corners	0.550	0.099	0.054	0.005	-
Lower corners	0.550	7.901	4.346	34.334	-
Comp. flange	1.205	0.035	0.042	0.001	-
Tension flange	1.205	7.965	9.598	76.447	-
Comp. stiffener	0.540	0.480	0.259	0.124	0.013
Tension stiffener	<u>0.540</u>	7.520	<u>4.061</u>	<u>30.537</u>	<u>0.013</u>
	7.302		31.321	226.961	0.569

$$y_{cg} = 31.321 / 7.302 = 4.289 \text{ in.}$$

$$I_x' = Ly^2 + I_1' - Ly_{cg}^2 \\ = 226.961 + 0.569 - 7.302 \times 4.289^2 = 93.206$$

$$I_x = I_x' t = 93.206 \times 0.07 = 6.524 \text{ in.}^4$$

$$S_e = I_x / y_{cg} = 6.524 / 4.289 = 1.521 \text{ in.}^3$$

$$M_n = S_e F_y = 1.521 \times 50 = 76.06 \text{ in.-kips}$$

$$M_a = M_n / \Omega = 76.06 / 1.67 = 45.54 \text{ in.-kips}$$